



# Micropower Power Supply Beats Off-The-Shelf Solutions

Steve Kendig

[info@a2eTechnologies.com](mailto:info@a2eTechnologies.com)

A2E Technologies, San Diego, Calif.

Designers of high-sensitivity, low-noise preamplifiers recognize the benefits of galvanic isolation to reduce noise. Besides the noise benefits of isolation, some preamps have further requirements, such as the ability to float at a large dc offset voltage. Accommodating this requirement with off-the-shelf solutions may result in high cost and the addition of large components.

Designers can craft a high-isolation micropower dc-dc converter using a telecom transformer. The design is extremely low in cost, and it requires very little board area.

The topology is a basic half-bridge converter. Unique aspects include use of a tiny, off-the-shelf telecom transformer for the isolation barrier and an n-channel MOSFET driver (U1) instead of the typical discrete MOSFET totem pole (see the figure).

The design works by driving the input to the MOSFET driver with a 50% duty-cycle square wave that has a frequency of 500 kHz to 1.5 MHz. This signal can be generated within existing programmable logic or by adding a crystal or CMOS-based oscillator.

The MOSFET driver impresses a 12-V p-p signal on transformer T1, which is filtered by the combination of the transformer's primary magnetizing inductance and capacitors C1 and C2. This filtering generates a dc voltage at the junction of C1 and C2 with a value of  $V_{CC}/2$ .

The transformer couples the resulting square-wave signal to the output of the transformer, where it's rectified by Schottky diodes D1 and D2. The rectified signal is then filtered by output capacitors C3 and C4, producing a clean dc voltage of  $\pm V_{CC}/2$ . This output voltage obviously isn't regulated, but it will be constant over a small range of output current sufficient to drive

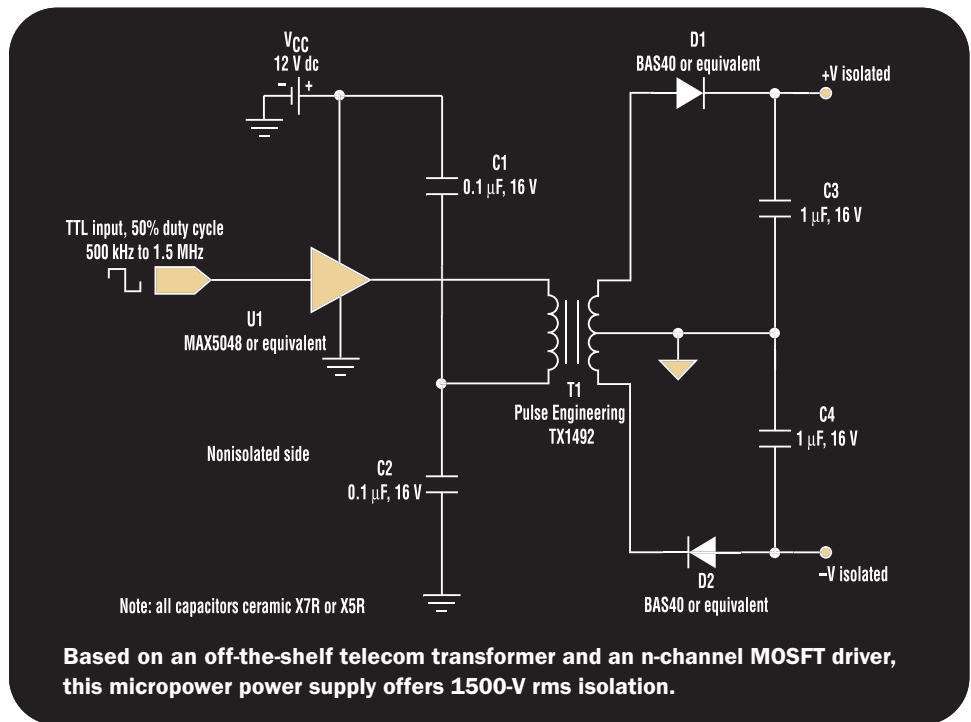

micropower-type op amps.

Input capacitors C1 and C2 ensure dc balance on the transformer primary. Therefore, they will prevent any dc saturation of the transformer. The output voltage can be adjusted by increasing the value of  $V_{CC}$ , assuming the gate driver can accept voltages higher than 12 V.

Another way to increase the voltage is by adjusting the turns ratio of the transformer, which may be available by special order from the transformer manufacturer. This design will provide up to 1500 V rms of isolation between primary and secondary. **ED**

**ED Online 10954**

**STEVE KENDIG**, senior hardware engineer, earned a BSEE from the University of New Hampshire. He holds two patents dealing with precision timing redundancy.