

design Variable Gain Amplifiers

FAQs

Don Tuite
Analog/Power Editor

FREQUENTLY ASKED QUESTIONS

ED ONLINE 18875

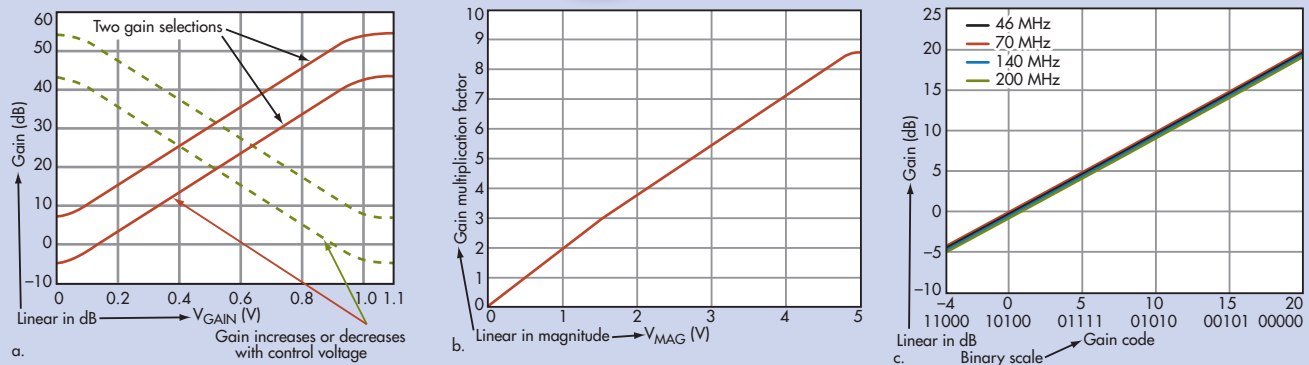

1. Analog gain control offers multiple advantages. First, it is linear in terms of both dB (a) and magnitude (b). (Figure 1a also demonstrates consistency in gain control regardless of whether gain is being adjusted up or down.) Digital control (c) offers linearity in terms of dB and consistency, but in discrete steps.

What are VGAs?

Variable gain amplifiers (VGAs) are signal-conditioning amplifiers with electronically settable voltage gain. There are analog VGAs and digital VGAs, or DVGAs. An analog voltage controls the gain in both, which differ in how it is applied. A digital-to-analog converter (DAC), a functional source, or a dc source can provide the control. VGAs are available from dc to gigahertz frequencies and in a variety of I/O configurations.

How is VGA gain controlled?

In analog VGAs, gain in dB is a linear function of input voltage (Fig. 1a and 1b).

The datasheet will provide an intercept point for 0-V input and a slope in terms of dB/V on the V_{GAIN} pin. With DVGAs, a binary code or digital word applied to a digital port or register controls the gain. The word can be serial or parallel, and it can operate like a register with an address somewhere in the digital portion of the system. In either case, the binary input steps are weighted in dB (Fig. 1c).

What applications use VGAs?

VGAs help tame signals that exhibit wide dynamic range. Consider cell-phone receivers. Depending on the distance between the basestation and cell

phone, their input signal levels range from a few microvolts to volts. Similar situations with wide dynamic range are found in scientific, industrial, and medical applications—such as the “front ends” of measurement equipment and ultrasound imaging, both for biological diagnostics and industrial fault analysis.

Broadly speaking, VGAs are used in two circumstances. The first encompasses all those situations where the circuit designer must match an input signal level to the full-scale input of a device such as an analog-to-digital converter (ADC) or an FM discriminator. The second addresses situations in which the

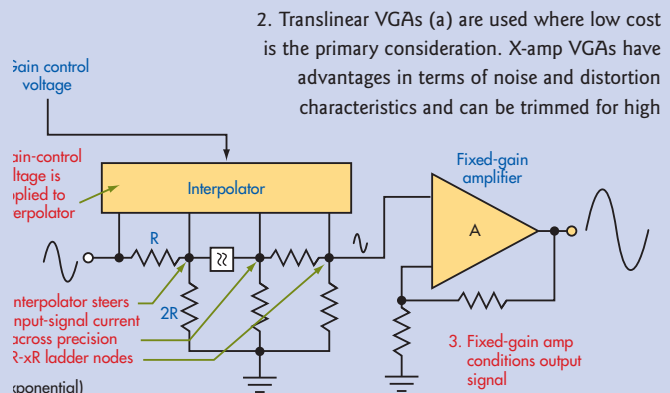
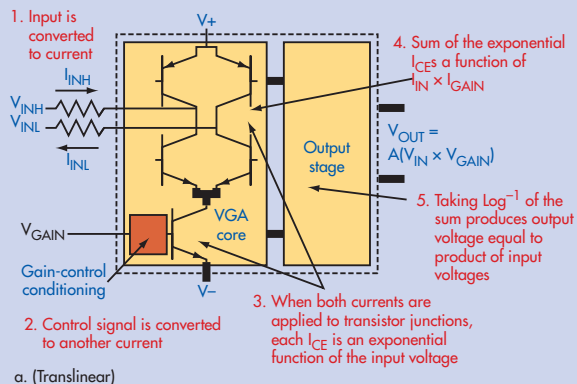

designer must scale a fixed input voltage to compensate for variable losses, for example, to adjust the voltage level to a transmission line. In these applications, VGAs reduce bill-of-materials cost and save space, but they also offer better performance in terms of noise, distortion, and power consumption.

What kinds of internal architectures do VGAs use?

Two approaches are in wide use: trans-linear and exponential amplifiers. The trans-linear core uses the principles of the diode equation, which expresses the exponential relationship between junction current and base voltage in bipolar devices (Fig. 2a). Exponential-amplifier VGAs combine a precision-matched R-xR ladder attenuator and an interpolator, followed by a fixed-gain amplifier (Fig. 2b). There are six to eight “rungs” on the ladder, and the interpolator circuit sweeps across that ladder in response to the VGA’s control voltage.

What are some common real-world applications for VGAs?

VGAs can be found in communications, cable TV, medical equipment, and industrial applications. In medical and industrial scanner applications, the VGA is used in specialized circuits called time gain controls (TGCs), which compensate for attenuation in the medium being probed. In medical ultrasound systems, echoes from structures deep in the body must be amplified more than echoes close to the skin.

In communications, VGAs function as automatic gain control (AGC) amplifiers or as “output” VGAs that adjust the voltage input to a cable system. The device’s gain maintains signal integrity and amplitude despite the length of the cable or number of receivers attached.

What kinds of applications favor analog or digital VGAs?

Two applications that favor analog VGAs utilize time gain control: ultrasound scanners and phased-array radars. Both involve a massive number of parallel amplifiers that all require a common gain control. That’s easier to achieve with a single analog control voltage routed to each VGA.

On the other hand, consider a cable TV system in which the level of the upstream signal from the consumer’s set-top box is adjusted for cable attenuation by a downstream signal from the cable company’s head-end. This would be a case for a digital VGA.

ANALOG DEVICES
product Q&As

Digitally Programmable VGA with Transmit Driver

The AD8260, ideal for industrial and automotive cabling applications, includes a high-current driver, usable as a transmitter, and a low-noise digitally programmable VGA, which is usable as a receiver. The receiver consists of a single-ended input preamplifier and a linear-in-dB, differential-output VGA. It has a gain span of 30 dB in 3-dB steps and a -3-dB bandwidth of 230 MHz. The driver-amplifier delivers ±300 mA on a 3.3-V supply, well suited for driving low impedance loads. It is available in a 32-lead LFCSP and operates over -40°C to 105°C.

Versatile, Wide-Bandwidth, DC-Coupled VGA

The AD8336 is a general-purpose, low-noise, single-ended VGA usable over a large range of supply voltages. The device provides 115-MHz bandwidth over a gain range of 60 dB, with a slew rate of 550 V/ms for a 2-V step. It is available in a 16-lead LFCSP and operates over the industrial temperature range of -55°C to 125°C.

Ultralow Distortion Digitally Controlled Dual VGA

The AD8376 is the industry’s first dual-channel, digitally controlled, wide-bandwidth VGA that provides precise gain control, high IP3, and low noise. It achieves 50-dBm output IP3 at 200 MHz and provides a broad 24-dB gain range with 1-dB resolution. This highly integrated solution replaces discrete circuits comprising digital attenuators and IF amplifiers while consuming only 130 mA per channel. It is available in a 32-lead LFCSP.

41-dB Range, 1-dB Step Size, Programmable Dual VGA

The AD8372 provides precise gain control, high IP2, good distortion performance, and moderate signal bandwidth, making it suitable as a gain control device for a variety of multichannel receiver applications. The AD8372 provides a broad 41-dB gain range with quiescent current of typically 106 mA per channel in a small 32-lead LFCSP.

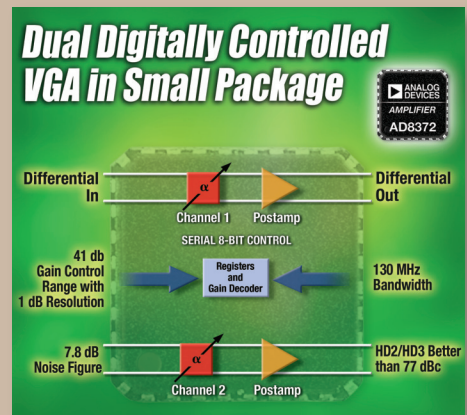
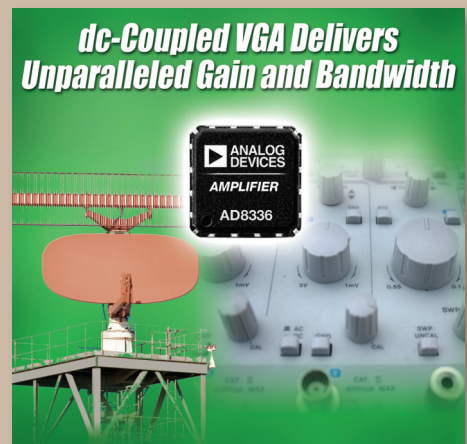

Learn more about ADI’s variable gain amplifier portfolio at www.analog.com/VGA-FAQ.

EXPERIENCE THE DIGI-KEY DIFFERENCE

VISIT US FOR ALL YOUR ANALOG DEVICES PRODUCTS AT DIGIKEY.COM/ADI TODAY!